

Residue use

The study indicated that the industry is increasing its use of residues. Prior to 1965, only four county sawmills operated wood chipping facilities. By the end of 1966, all but the two smallest had chipping facilities in operation. Recent installations which use other residue fractions are the bark recovery and sawdust-fired steam boiler at one plant and the system for fuel use of sander dust in another. The Shasta County operations recovered nearly 1,750 lbs per 1,000 board ft in 1966, compared with the statewide average of 1,200 lbs per 1,000 ft of logs processed in 1965.

However, only slightly more than half of the residue generated in the county is presently being put to economic use. From a qualitative standpoint, the problem is even more difficult in that a large percentage of the material usable under the technology and economics of today is already being recovered. Although the county industry fares well in comparison today with the rest of the state, effective government control of sources of air pollution can be anticipated with certainty—the only matter of doubt is when it will come. The wood manufacturing industry can and must find solutions to the problem of how to cope with the remaining residue or it will be unprepared for the controls that are inevitable in the future.

William A. Dost is Extension Forest Products Specialist, Agricultural Extension Service, University of California, Berkeley.

TABLE 1. WOOD RESIDUES AT SHASTA COUNTY FOREST PRODUCTS COUNCIL PLANTS IN 1966 (millions of cubic feet)

| | Developed | Used | Unused |
|-------------------------|------------------|------------------|------------------|
| | millions cu. ft. | millions cu. ft. | millions cu. ft. |
| Bark—Log yard | 2.32 | 0.00 | 2.32 |
| —Mill deck | 10.23 | 3.66 | 6.57 |
| Fine wood | | | |
| dust—green | 7.03 | 4.77 | 3.11 |
| —dry | 0.85 | | |
| shavings—green | 2.13 | 3.70 | 3.32 |
| —dry | 4.89 | | |
| Coarse wood | | | |
| chippable | 18.39 | 14.49 | 3.90 |
| dry trim & other losses | 6.83 | 2.25 | 4.58 |

TABLE 2. WOOD RESIDUE TONNAGE AT SHASTA CO. FOREST PRODUCTS COUNCIL PLANTS IN 1966

| | Developed | Used | Unused |
|-------------------------|-----------|---------|--------|
| | tons | tons | tons |
| Bark—Log yard | 25,807 | 0 | 25,807 |
| —Mill deck | 108,544 | 37,012 | 71,532 |
| Fine wood | | | |
| dust—green | 89,924 | 57,406 | 43,516 |
| —dry | 10,998 | | |
| shavings—green | 20,805 | 44,504 | 23,941 |
| —dry | 47,640 | | |
| Coarse wood | | | |
| chippable | 236,722 | 175,109 | 61,613 |
| dry trim & other losses | 81,897 | 27,082 | 54,815 |

PLASTIC SHELTERS

for crop growth experiments in the field

V. H. SCHWEERS

R. M. DAVIS, JR.

SHELTERS ARE often necessary in experimental work with growing crops to protect research results from the influence of insects or insect-transmitted viruses or other diseases—without greatly altering the other important factors of environment such as light, soil and temperature. This article resulted from a study of the low sugar problem threatening cantaloupe production in several areas of the San Joaquin Valley. It describes a simple inexpensive framework covering a ground area 20 by 30 ft, and reports measurements of light, temperature and humidity within several such structures covered with various combinations of polyethylene and cheesecloth.

The main frame was a 2- by 4-inch truss at each end and middle of the shel-

ter of the design as shown in the sketch. These were joined by 2 by 4 sills^(a), 2 by 4 purlins^(b), and a 2 by 4 ridge-board^(c). The covering rested on ¼-inch marine plywood ribs, 2 inches wide and 8 ft long, spaced at 3-ft intervals, and attached to sill, purlin and ridge as shown by the dotted line in the sketch. The houses were placed with the ridge running east and west. At the entrance on the end of the house, a double door, plastic-covered vestibule was built as an extra insect-proofing precaution.

An exhaust fan was installed in each house which had the capacity to move the total house air volume each minute. Temperature and humidity measurements were made with fans both off and on. The fan exhausted at the midpoint of one side. For the exhaust stream, an insect proof, cheesecloth covered cage, 3 by 3 by 8 ft extended outside the house. A ¼-inch

CROSS SECTION OF FIELD CROP SHELTER SHOWING CONSTRUCTION DETAILS AND SPECIFICATIONS

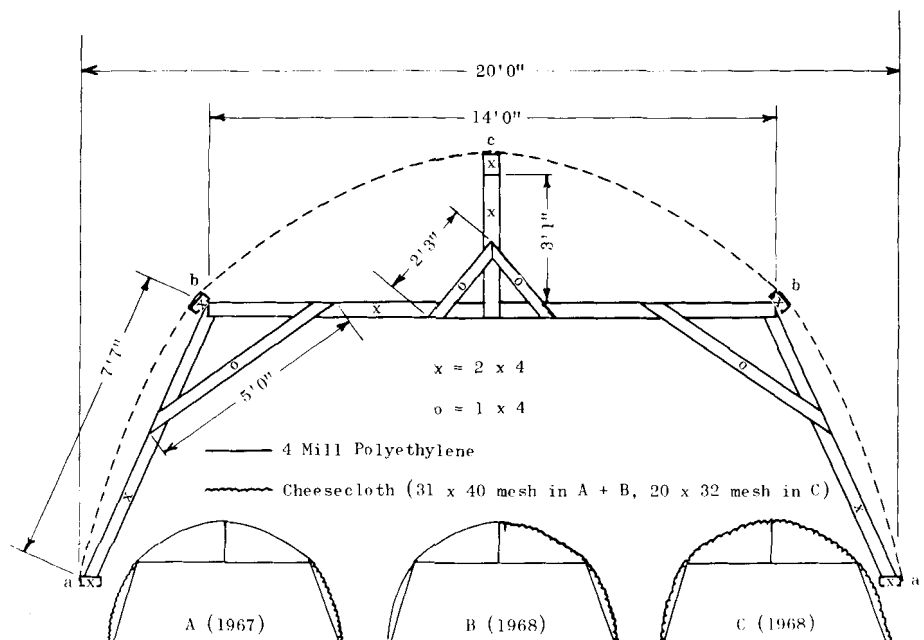

building wire screen on the inside prevented bees from being drawn into the fan. Under certain combinations of polyethylene and cheesecloth, the fans were found to be unnecessary for controlling temperature (table 1).

In 1967, three houses were built, all covered as shown in sketch detail A. Polyethylene (4 mil) was extended across the top ribs, and cheesecloth (31- by 40-mesh) on each side. In 1968, two structures were covered as shown in sketch detail B. The extension of cheesecloth to the ridge was designed to permit the exit of hot air otherwise trapped under the polyethylene. On one of these structures, the polyethylene covering was on the north side, on the other it was on the south side. A third structure, in 1968, was covered completely with 28- by 32-count cheesecloth (sketch detail C) instead of the 31- by 40-mesh used on the side of the other houses. The ends of the structures were covered half with plastic and half with cheesecloth, with the cheesecloth occupying a central panel.

The life of the cheesecloth was about three to four months, and less where it contacted the ground. Its attachment at the base of the structures should be kept above ground level.

Differences

Average differences between the environmental measurements inside and those in the open field are shown in table 1. Environmental variables inside and outside of the houses were equivalent during the night. Relative humidities approached 90 per cent at night. Afternoon temperatures were commonly about 100°F and relative humidity was 35 to 40 per cent, the vapor pressure about 16mm, Hg. The mean sunlight intensity during June and July was greater than 10,000 foot candles in the open field.

Temperatures inside the structures approximated outside temperatures except in the structure as covered in sketch detail A, on very hot afternoons with the fan off. The structures covered as in sketch B, permitted a fair approximation of outside temperatures, even without fans. A slightly cooler environment than the field was provided by the cheesecloth covered structure (sketch C). Radiant heat seemed more intense under the polyethylene than under the cheesecloth, and this was detected objectively by the soil temperature in containers used in 1968. Mean soil temperatures of containers illuminated through plastic were



Field crop shelter used in 1968 tests as shown above had top and end sections covered with polyethylene, and lower side and exhaust tube cheesecloth-covered. Vestibule at end of shelter is also covered with plastic.

4 to 5 degrees higher in the afternoon than those illuminated through cheesecloth, whether the plastic covered the north or south side (the cheesecloth covering the opposite side). Temperatures of the soil in the containers were higher than those of the soil in the open field. In 1967, plants were grown in the parent soil mass within the structures, and soil temperature was the same as that in the open field.

Light intensity was somewhat diminished in the structures sufficient to promote an increase in leaf size and plant size, but not enough to decrease the concentration of soluble solids in fruits of the cantaloupe plants which were grown. The percentage of outside illumination reaching the interior of the houses is given in greater detail in table 2. The slope of the covering with respect to the direction of the sun's rays affected transmittance more when cheesecloth was used than when polyethylene was used.

Relative humidity was somewhat higher inside the structures than outside. The even higher relative humidity in the type C structure (completely cheesecloth-covered) is due to the lower temperature in the structure and is misleading. A more accurate impression is given by the vapor pressures calculated for the various conditions (table 1).

Small hives of young bees (nuclei) were used for pollination. The older bees died fighting the enclosure on the first two days, but newly emerging bees were quiet and busily worked the blossoms. They were supplied with a 33 $\frac{1}{3}$ per cent sucrose solution in 1967 and an extra frame of honey in 1968. Pollination was

about five times more efficient than in the small cages used in 1966. On a lineal-foot-of-row basis, the production of melons (one per foot) was about half that produced outside the cages.

The shelters effectively excluded such small insects as leafhoppers, leafminers, aphids, springtails and ants. Mites appeared inside tight structures, so precautionary control measures for mites will be required. No mosaic symptoms were seen on plants in the houses, though common on plants outside.

Vincent H. Schweers is Farm Advisor, Tulare County; and Ralph M. Davis, Jr. is Associate Olericulturist, Vegetable Crops Department, University of California, Davis, stationed at Kearney Field Station, Reedley.

TABLE 1. DIFFERENCES BETWEEN INSIDE AND OUTSIDE MEASUREMENTS OF ENVIRONMENTAL VARIABLES OF EXPERIMENTAL COVERED STRUCTURES

| Mean differentials, 10AM-4PM | Structure Cover Type | | |
|--|-------------------------|-------------|-------------|
| | A (1967) | B (1968) | C (1968) |
| Temperature inside minus outside, °F fans on | 1.7 (2.6 from 1-3PM) | 1.6 | -0.7 |
| fans off | 2.5-7.5 | 1.6 | -0.7 |
| Light intensity, (inside/outside) x 100 | 90 | 88 | 86 |
| Relative humidity inside minus outside | 2.0 | 2.2 | 6.0 |
| Vapor pressure inside minus outside, mmHg | 2 | 2 | 2 |

TABLE 2. ILLUMINATION UNDER VARIOUS COVERINGS, AS A PER CENT OF OUTSIDE SUNLIGHT INTENSITY

| Covering Material | Slope of Covering | |
|--------------------------|-------------------|-------|
| | North | South |
| 4-mil polyethylene | 91 | 91 |
| 28 x 32 mesh cheesecloth | 83 | 89 |
| 31 x 40 mesh cheesecloth | 80 | 86 |